

VesselCheck ST2

Non-Invasive Tank Level Measurement System

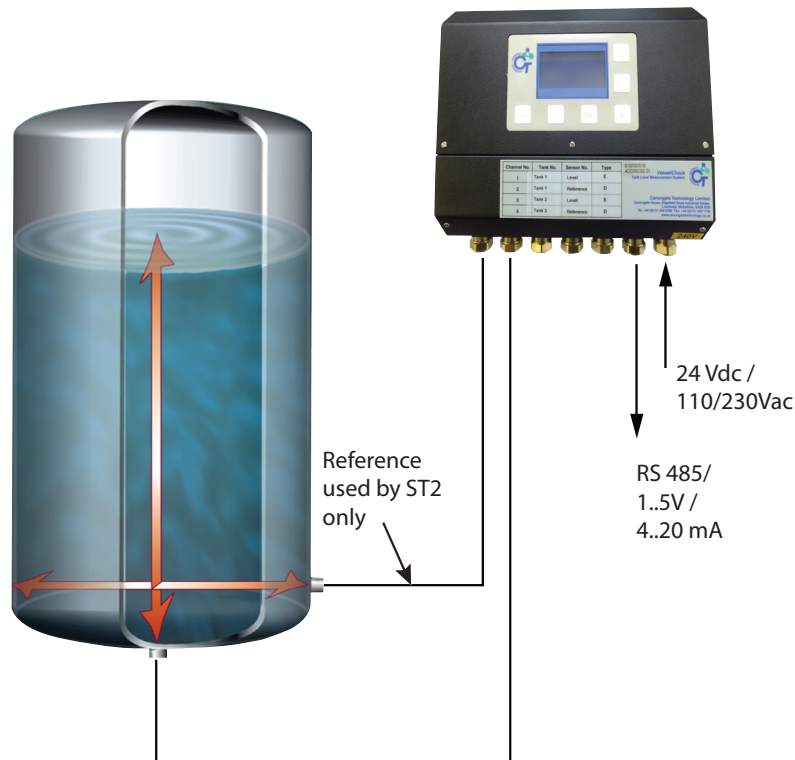

Data sheet : ST2/2012



Principle of Operation

The ST2 uses two small ultrasonic sensors bonded or clamped to the outside walls of the vessel - one on the bottom of the vessel and the other on the side, to compensate for variations in sonic velocity and temperature. Signals from the transducers are fed into the processor and displayed locally and/or output to the plant control system. The system calculates the height and volume of the liquid in the tank from the time taken for the signal to be received from the liquid surface.

Features:

- Truly non-invasive sensing technique
- Sensors bonded to outside of tank base and side wall
- 20 point calibration table
- Optional local display & keypad
- 4..20mA / 1..5V analogue outputs
- RS485 / 232 Modbus serial communications
- ATEX / IECEx approved sensors for hazardous areas available

Benefits:

- Fast, reliable and accurate tank contents measurement
- Easy installation - no tank break-in, easy retrofit to existing tanks
- No down-time during installation
- No moving parts – little or no maintenance required



ATEX Sensor shown

Vessel Check ST2 - Technical Specification

Accuracy	+/- 2mm or better
Repeatability	+/-0.5mm
Measuring Range	75mm to 25 metres / 3" to 80 feet (application dependent)
Temperature Range (sensors)	-20°C to +125°C / -4°F to 257°F
Hazardous Area Approval (sensors)	Ex mb IIC T5 Gb (-20°C ≤ Ta ≤ 60°C) Cert No. IECEx BAS 11.00.0039X
Analogue Outputs (optional)	4..20mA (active) / 1..5Vdc
Digital Alarm Outputs (optional)	4 x Solid state active outputs (>17Vdc)
Max distance (processor to sensor)	100m
Serial Outputs	RS232, RS485, Modbus RTU / ASCII
Power Supply	24Vdc (N/A for haz area applications) or 110 / 230 Vac, 50/60Hz.
Protection Rating (processor)	IP65
Protection Rating (sensor)	IP66
Sensor Material	Tufnol / Ertacetal
Processor Enclosure Material	High Impact Polystyrene
Display Size (optional)	70x43mm / 2.75x1.7"
Dimensions (processor / display unit)	270x215x85mm / 10.5x8.5x3.5"
Weight (processor)	1.4Kg, 3lbs

Product Identification Code (PIC)

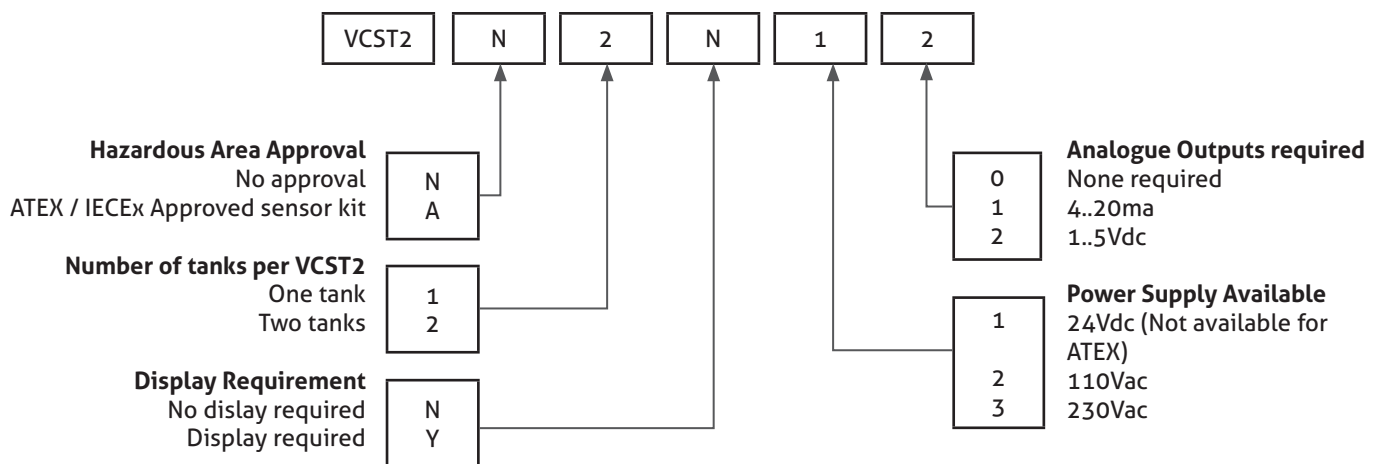

NOTE
Cable (C) must be installed to comply with installation standard IEC0079-14

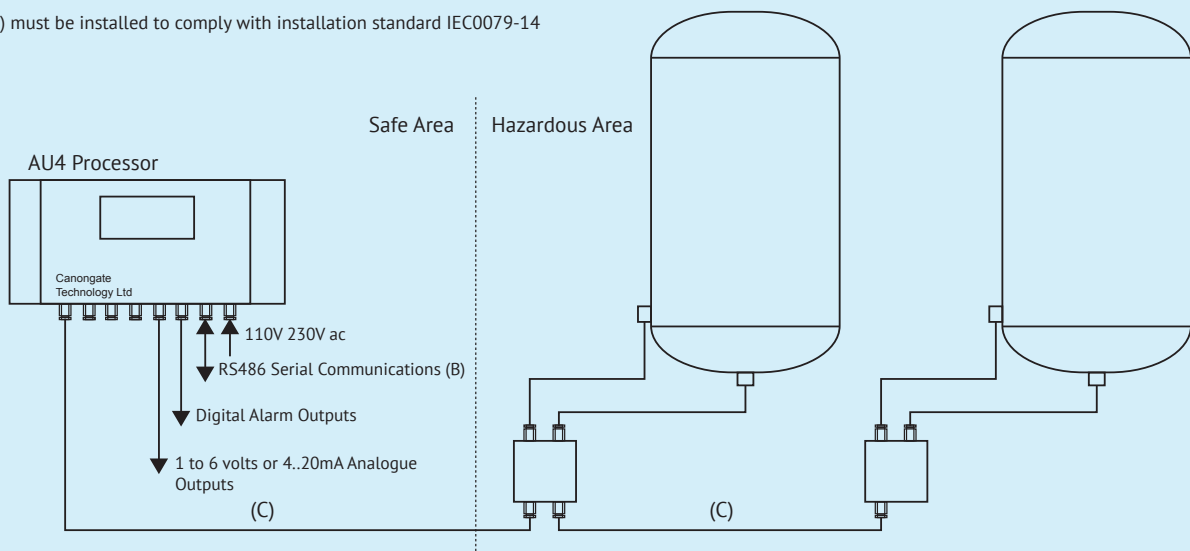

VesselCheck Range Overview

Typical Application	Maximum Height	Number of Tanks	Hazardous Area Approval	Display	Variants
High accuracy: beer, spirits, acids, solvents, water, LPG spheres, wine	20 metres	2	Optional	Optional	ST2
Less accurate: LPG spheres, wine	20 metres	4	Optional	Optional	ST4
Fuel, water, light oils, acids	3 metres	1	No	Optional	ST1
LPG, small spirit tanks	3 metres	1	Sensor Only	Optional	ST1(A)
LPG, solvents, acids, fuels, Sulphur Dioxide, Chlorine	3 metres	1	Sensor & Processor	Yes	ST1AD
Refrigerant Gas	2 metres	1	No	Optional	ST1(R)
Graphic colour operator interface terminal & evaluation unit for use with VesselCheck systems	N/A	Up to 32	No	Yes	VCHMI



Excellence the World can Measure™

Rotherm Canongate Technology

Midlothian Innovation Centre, Pentlandsfield, Roslin EH25 9RE United Kingdom

T: +44 (0) 131 448 0786 **E:** sales@ct-uk.co.uk **W:** www.ct-uk.co.uk