



NEW

RPS-401A-80P

Features

- Adjustable Zero & Span
- Sensing Range 8-80 in.
- Narrow Sensing Beam
- LED Strength Indicator
- Short Circuit Protected
- Wide Temperature Range
- Selectable Inverted & Non-Inverted Outputs
- Analog Current & Voltage Outputs
- Reverse Polarity Protected
- Self Contained Barrel Housing
- Input Voltage 20-30 VDC
- RPS-401A in PVC Housing
- Chemical Resistance (PVC)

The RPS-401A-80P analog ultrasonic sensor is mounted in a PVC barrel housing and is completely self contained. It is powered by 20-30 VDC and is reverse polarity protected. It also has a narrow beam angle which enables it to get into tight places. A flat target can tilt up to 10 degrees and still be detected.

The RPS-401A-80P has 2 short circuit protected analog outputs, 4-20mA and 0-10 VDC. These outputs can easily be inverted and can be scaled over almost any range by means of adjusting the zero (P1) and span control (P2). The (P1) potentiometer must be adjusted first. Both analog outputs can be used at the same time.

For set-up purposes an LED strength indicator is provided.



This LED is Green when not detecting and changes to a bright Red as a target moves into place depending on how much reflected signal is coming back from the target. The frequency of operation for the RPS-401A-80P is 140kHz.

The RPS-401A-80P is constructed of PVC. The barrel measures 30mm x 105mm. A standard 6' cable is provided.

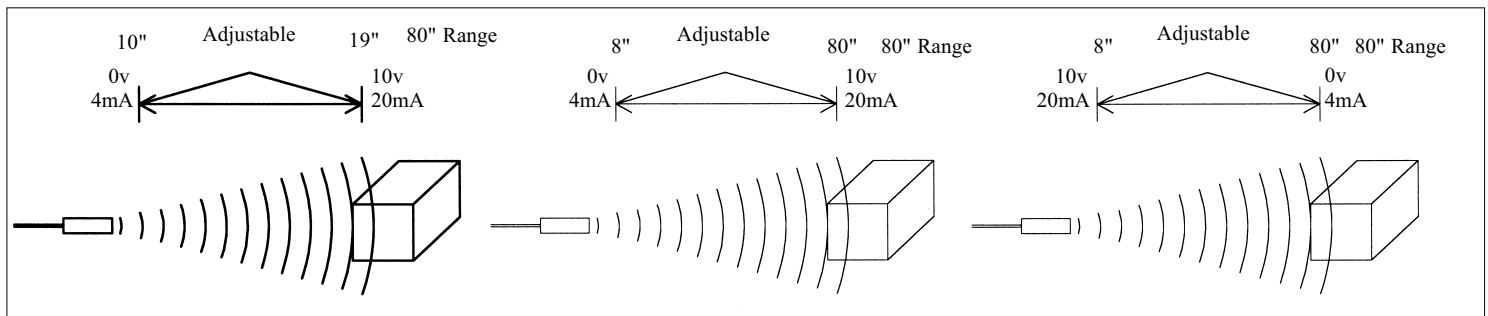

Minimum Analog Ranging

Analog sensing in the Minimum sensing configuration means detecting an object over a 9" range with the RPS-401A-80P. This 9" span can be adjusted to occur over any part of the sensors range. For example it could be adjusted to occur from 8" to 17" or 25" to 34". This is done by means of the two potentiometers on the sensor. This sensor has a 8:1 adjustment ratio on its analog output, meaning that the RPS-401A-80P has a maximum span of 72" (range 8" to 80"). The analog output can also be adjusted anywhere between the 8" and 80" range. These adjustments are made by the two potentiometers on the sensor. With no more than two adjustments of each potentiometer the desired span will be achieved.

Maximum Analog Span

Analog sensing in the Maximum ranging configuration means detecting an object over an 8" to 80" range with the RPS-401A-80P. This 72" span goes from the sensors minimum sensing distance of 8" to its maximum sensing distance of 80". The adjustment procedure is the same as described in the minimum analog ranging section. The RPS-401A-80P in the maximum ranging configuration detects an object over a 72" range. This span goes from the sensors minimum sensing distance of 8" to its maximum sensing distance of 80". This sensor also has a 8:1 adjustment ratio on its analog output so its minimum analog ranging capability is a span of 9". These adjustments are made by the two potentiometers on the sensor.

Inverted Analog Outputs

The RPS-401A-80P has the ability to invert its analog outputs, meaning that the current or voltage will decrease as distance from the sensor increases. For the current output to be inverted the voltage output needs to be tied to the positive of the supply voltage of the sensor. This then will invert the current output to 20mA - 4mA. To make the voltage output inverted 10v - 0v the current output needs to be tied to the positive of the supply voltage. In the standard mode of operation (non-inverted) P1 adjusts the near point 4mA (0v) and P2 adjusts the far point 20mA (10v). In the inverted mode of operation P1 adjusts the near point 20mA (10v) and P2 adjusts the far point 4mA (0v). Always adjust the (P1) potentiometer first.

Specifications:

Operational Range: Adjustable 8" to 80"
 RPS-401A-80P

Power Input: 20 - 30 VDC Reverse Polarity Protected
 Input Current: 90 Milliamps Max.
 Ambient Temperature: -40° to 60°C or -40° to 140°F
 Humidity: 0% - 95% Non-Condensing
 RPS-401A-80P Housing: PVC Housing with a PVC sensing face
 Outputs:
 Current Sourcing Analog Output
 4-20mA Inverted & Non-Inverted
 (Load 0 ohm to 500 ohm maximum)
 Analog Voltage Output
 0-10 volts Inverted & Non-Inverted
 (Load 500 ohm to infinity)
 Short Circuit Protected

Transducer Frequency: 140 kHz
 Response Time: 35mS Typical
 Weight: Sensor only 4 ounces
 Sensor plus cable shipping weight 9 ounces

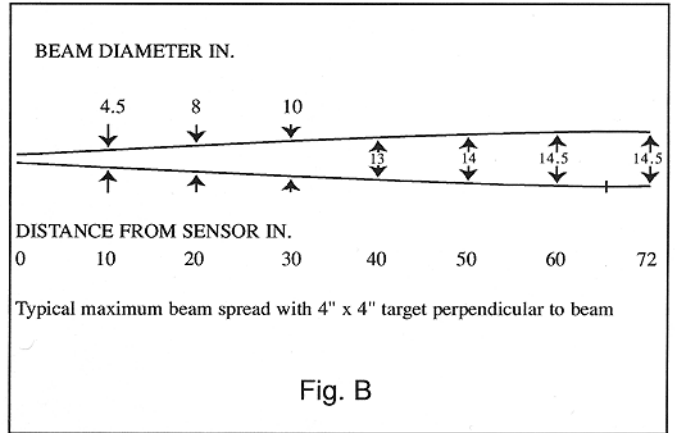
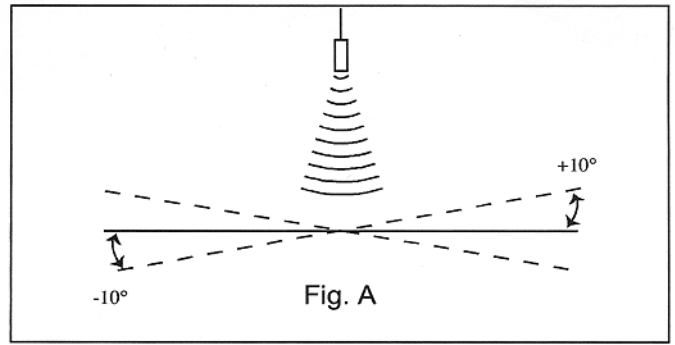

Mounting Consideration:
 The performance of this sensor can be influenced by direct metal contact. This zone is 12mm/.50" measured from the sensor face. See Fig. G

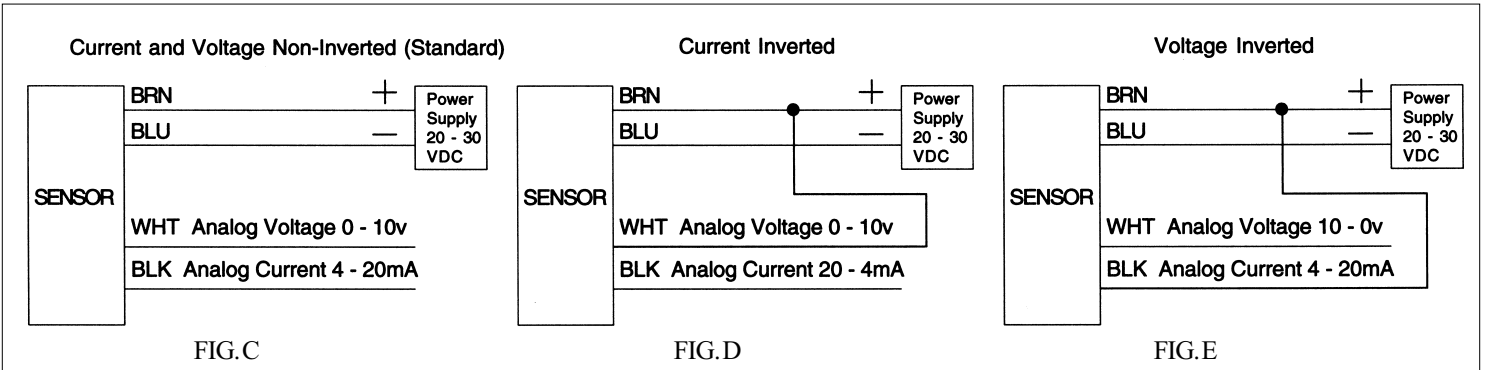
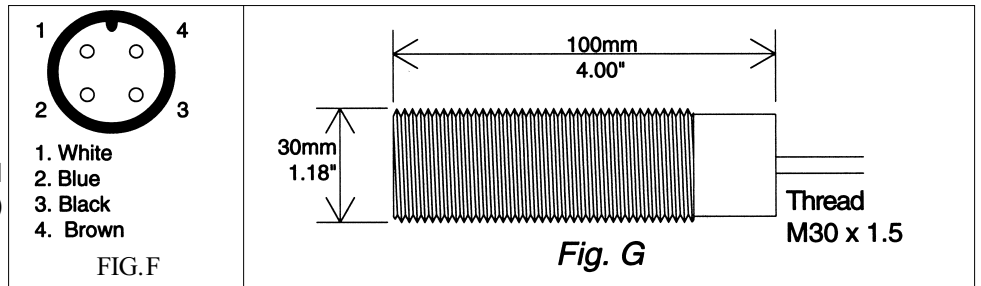

Figure:

- A - Angle of Tilt
- B - Beam Spread
- C - Wiring Diag. RPS-401A Standard
- D - Wiring Diag. RPS-401A Current Inverted
- E - Wiring Diag. RPS-401A Voltage Inverted
- F - Connector Diag. "QD" option (Male View)
- G - Mounting Dimensions



PART NUMBER	RANGE	OUTPUT
RPS-401A-80P	8" to 80"	0 - 10VDC and 4 - 20mA Analog
RPS-401A-80P-QD	8" to 80"	0 - 10VDC and 4 - 20mA Analog - Quick Disconnect
5000118-3		6' Cable for "QD" option
5000118-6		16' Cable for "QD" option



Wesmar AB

Box 1120 • 164 22 Kista
 Finlandsgatan 24 • 164 74 Kista
 Tel. 08 544 715 50 • Fax. 08 544 715 60
 info@wesmar.se • www.wesmar.se

(815) 338-5800 / FAX: (815) 338-5803

935 Dieckman St., Woodstock, IL 60098, USA
<http://www.migatron.com>, e-mail: info@migatron.com