

SET/OSK2

Capacitive oil-on-water detector

INSTALLATION AND OPERATION INSTRUCTIONS

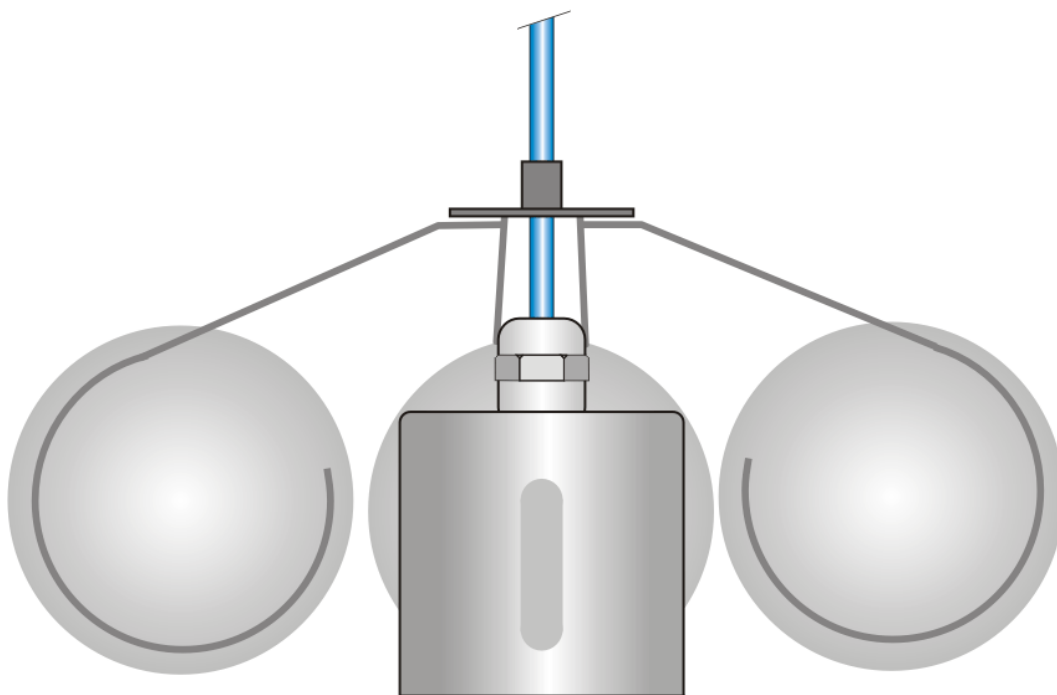

1. GENERAL

SET/OSK2 is a floating probe, which provides an alarm of at least 15 mm thick oil or hydrocarbon layer on water. The most common applications are for example inspection shafts and different kind of basins with altering liquid level. The probe is used with alarm control unit (e.g. LABKO SET-100, SET-101, SET-111 or SET-112).

SET/OSK2 is an apparatus of equipment group II, category 1 G (Directive 94/9/EC). The probe can be installed in zone 0/1/2 hazardous area.

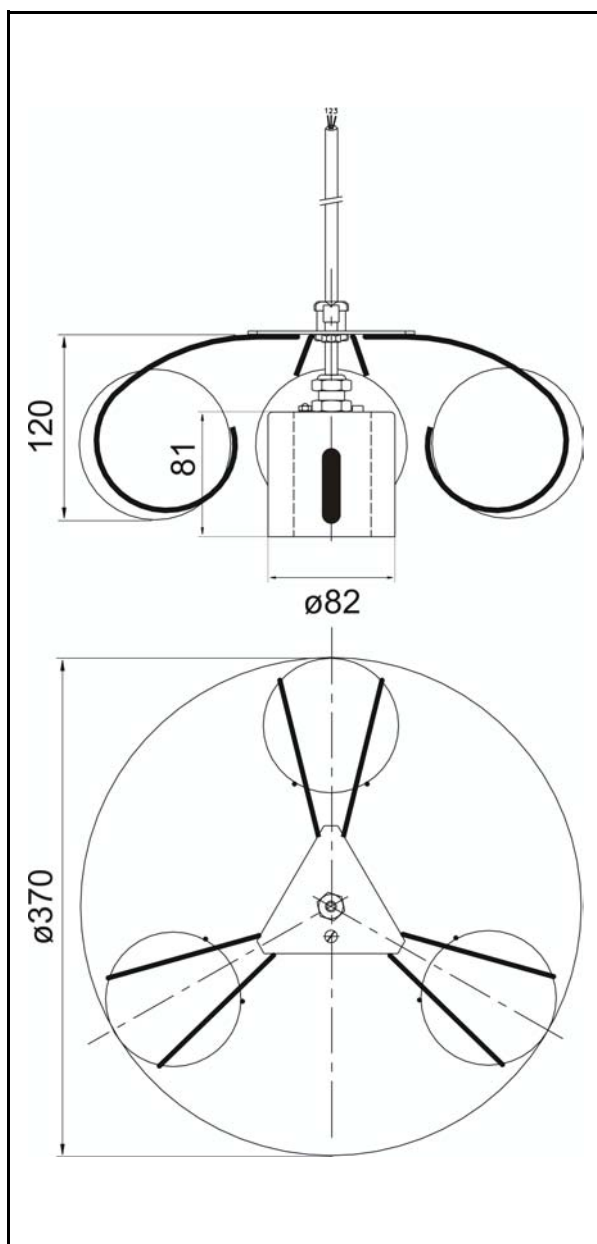

Picture 1. Dimensional drawing

2. TECHNICAL DATA

Control Units:	SET-100, SET-101, SET-111, SET-112
Cable:	Shielded, oil-proof instrumentation cable 3 x 0,5mm ² . Standard length is 5m. Can also be delivered according to the order with a maximum 15 m long cable. The cable can be extended with a similar instrumentation cable. The maximum pair resistance of the cable should not exceed 75 Ohm.
Material:	PVC, AISI 316
Ambient temperature:	-25.. +60 °C
EMC Emission Immunity	EN 50081-1 EN 61000-6-2
IP-classification: Sensor Junction box	IP68 IP67
Ex-classification:	 II 1 G EEx ia IIA T5 VTT 03 ATEX 009X U _i = 18 V I _i = 66 mA P _i = 297 mW C _i = 3 nF L _i = 30 µH U _n = 9...18 V
Operational principle:	Capacitive

The probe can be installed in zone 0/1/2 hazardous area with the following special conditions:
 - The ambient temperature is between -25 °C and +60 °C
 - The probe cable can be extended with the junction box type Labko LJB3-78-83 or LJB2-78-83. The junction box is of light metal so there may be sparks if the box is subjected to friction or impact. The box shall be grounded.

Application example

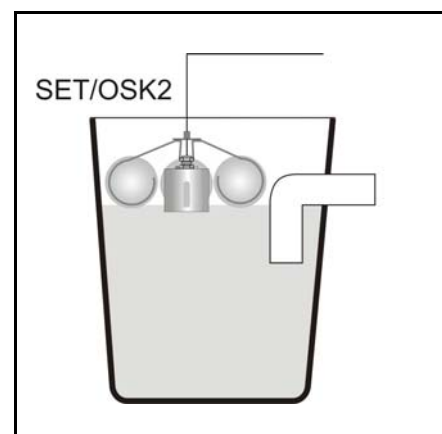

Picture 2. Oil alarm in water inspection shaft

3. CONNECTIONS AND INSTALLATION

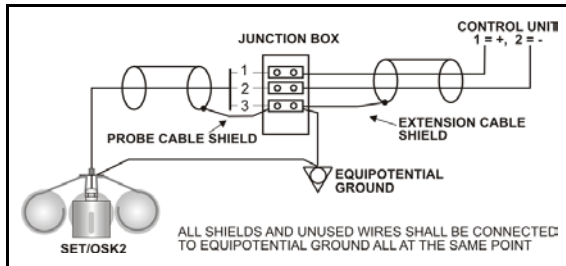

Picture 3. Wiring example

SET/OSK2 is equipped with a shielded 3-wire cable. The wires 1 and 2 shall be connected to the corresponding connectors (1 = +, 2 = -) in the control unit. Wire 3 shall be connected to equipotential ground together with the shield of the cable. Ground connector of the float frame shall be connected to equipotential ground. Please refer also to the installation instructions of the control unit.

The cable can be shortened or, when the control unit is located further away from the probe, the cable can be extended with the junction box, which is included in the delivery.

The probe floats freely on the liquid. **Therefore, please use long enough a cable to avoid hanging in the air in critical situations** (e.g. when the liquid level decreases).

When installing the SET/OSK2 probe into an explosion hazardous zone (0/1/2), the following standards need to be followed; EN 50039 Electrical apparatus for potentially explosive atmospheres - Intrinsically safe electrical systems "i", EN 60079-14 Electrical apparatus for explosive gas atmospheres. Part 14: Electrical installations in hazardous areas.
The probe shall not be installed into a space where caustic vapour, gas or liquid, such as aromatic and chlorinated hydrocarbons or strong alkalis or acids, can damage the equipment.

4. ADJUSTING SENSITIVITY

Adjusting the switching point is done as follows:

- Let the probe float freely on the water
- Lift up the probe as much as there is assumed to be oil or hydrocarbon layered on the water in alarm situation (the layer that should generate an alarm).
- if the control unit does not operate, adjust the SENSE trimmer slowly until the desired switching point is reached.

The sensitivity can also be decreased by adjusting the position of the sensor lower in the floating construction. Too sensitive settings cause unnecessary alarms if there are waves in the liquid.

To test the function of the probe, lift up the probe totally in the air. This should cause an alarm.

IF THE PROBE DOES NOT WORK

Make sure that the probe is properly connected to the control unit. The voltage between connectors 1 and 2 in the control unit should be 10,5...12V.



NOTE! If the probe is located in a hazardous area an Exi-classified multimeter must be used.

If the voltage is correct, measure the probe current as follows:

- Connect the ampere meter according to the picture below by disconnecting the conducting wire 1 from the central unit.

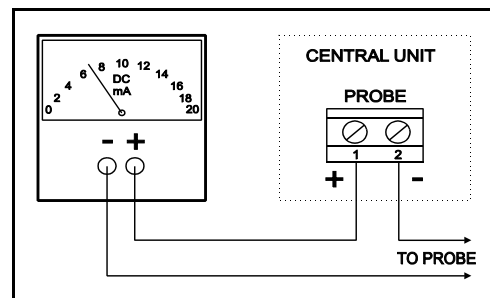

Picture 4. Measuring the probe current

- Measure the current.
- If the probe is clean and wholly in the air, the current should be 5..6mA.
- If the probe is wholly immersed in the water, the current should be approx. 12...16mA.

5. SERVICE AND REPAIR

The probes must always be cleaned down and tested after oil alarm or when carrying out annual maintenance. For cleaning, a mild detergent (e.g. washing-up liquid) and scrubbing brush can be used.

Service, inspection and repair of Ex-apparatus needs to be done according to standards IEC 60079-17 and IEC 60079-19.

