

YTE-101

TANK OVERFILL CONTROLLER INSTALLATION INSTRUCTIONS



1. GENERAL

YTE-101 is a sensor classified in **Equipment Group 1** (Dir. 94/9/EC) for controlling the overflow of flammable liquids.

Its operation is based on the change of resistance in a PTC resistor when temperature changes.



NOTE! The sensor may only be connected to a type-approved control centre.

YTE-101 can be installed in potentially explosive atmospheres rated in class 0/1/2. When installing, the appropriate standard must be taken into account EN 60079-14 installations in explosive atmospheres.

2. TECHNICAL SPECIFICATIONS

YTE-101	
Operating temperature	-35 °C...+80 °C
Maximum length	1,500 mm
Casing	IP 67, materials: Aluminium, Al casting
Ex classification	II 1 G Ex ia IIC T3 Ga
Special conditions (X)	VTT 07 ATEX 055X (Ta = -35 °C...+80 °C)
Connection values	Ui max. = 24 V Pi = 1 W Ri min. = 70 Ω, Ci ≈ 0 Li ≈ 0
Sensor element	PTC
Nominal resistance R _N ±) R _N	140 Ω ± 60 Ω

Manufacturing year in type label	xxx xxx xxXX where XX = manufacturing year
----------------------------------	--

Limits of operating range

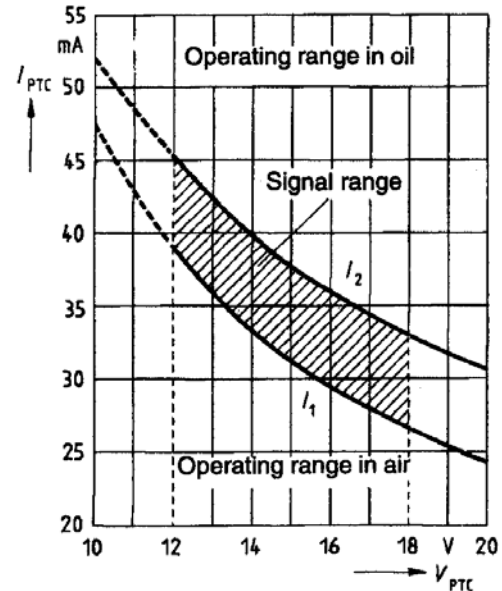

Figure 1. Characteristic curve of PTC resistor

2. STRUCTURE

YTE-101 consists of a connection box and a casing pipe mounted on the base of the box. The PTC element is installed into the casing pipe.

The material of both the box and the casing pipe is aluminium/AISI316.

The casing pipe that holds the PTC resistor in its base can be 1.5 m in length at the maximum. From the PTC, a connection cable is drawn to the connection box. The end of the cable holds a terminal strip to which the external cable is connected.

The structure of the external cable must comprise a protective jacket.

The protective jacket is connected to the contact screw inside the connection box.



WARNING! Contains light metal elements!
Danger of sparking!
When installed in a potentially explosive atmosphere, the location needs to be carefully considered in order not to damage the sensor and expose its metal parts to blows.

3. SENSOR INSTALLATION

When installing, standard EN 60079-14 is to be followed.

After the installation, two copies of the attached installation record for the overfill controller sensor are to be filled in.

Install the sensor in the aggregate in the tank casing, at least 350 mm away from the tank wall and filling pipe, in accordance with Figure 2.

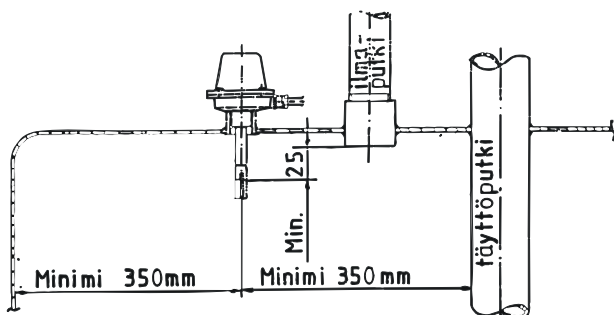

Figure 2. Installation dimensions

Install the sensor so that the indicator line of the termistor is at least 25 mm below the air hose opening.

With tilted and non-standard tanks, install the sensor in the lowest part of the tank or adjust it accordingly.

With combined tanks, install the sensor in the tank that fills up first. The filling order must be checked before installation.

Install the sensor so that the filling factor of the tank does not exceed 95%.

The adjustment height of the termistor can be calculated as follows:

Horizontal cylindrical tanks:

$$h \geq 0.1 \times D \quad [D = \text{diameter of tank}]$$

Rectangular tanks and vertical cylindrical tanks:

$$h \geq 0.05 \times H \quad [H = \text{height of tank}]$$

With vertical cylindrical tanks with a convex end,

the convex end (cover) must also be added to dimension h.

3.1 Sensor dimensioning and shortening

Cut the sensor pipe, preferably with a pipe-cutting machine, taking precautions not to damage the line.

Trim all sharp edges away. The cut length L can be calculated with the following formula: $L = (h + a + 63) \text{ mm}$, Figures 3 and 4. Tolerance for the cut length is $\pm 15 \text{ mm}$.

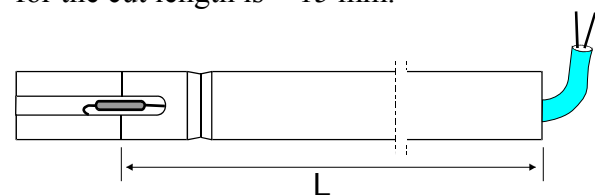

Figure 3. Sensor dimensioning

It should be noted that the adjustment height h presented in Figure 4 must always be at least as in Table 1, or it must be calculated with the formula.

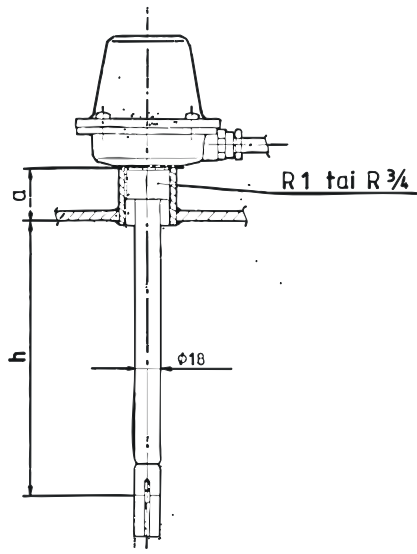

Figure 4. Sensor dimensioning

Horizontal cylindrical tanks; $h \geq 0.1 \times D$						
Ø D	1,000	1,250	1,600	2,000	2,500	3,000
h min.	100	125	160	200	250	300
Rectangular and vertical cylindrical tanks; $h \geq 0.05 \times D$						
height H	1,000	1,500	2,000	2,500	3,000	
h min.	50	75	100	125	150	

Table 1.

Tighten the sensor pipe carefully with a tension nut (Fig. 5).



Figure 5. Sensor pipe mounting

Install the TW901/905 inlet right next to the

filling pipe with adequate firmness. Place the plate TANK OVERFILL CONTROLLER next to the inlet.

If several filling pipes have been installed close to each other, clear indications must be given as to which inlet is meant for which tank and filling pipe. These indications must be permanent.

An oil resistant cable (at least $2 \times 1.5 \text{mm}^2$) with conductive protective jacket must be used as the cable. (e.g., ÖPVC-OZ-CY 2×1.5).

The cable must be protected with durable casing pipe from the tank service pit to the device plug.

Cable extension should be avoided, but when necessary, it should be made in an easily accessible location by using a certified (e.g., Ex e) connection box.

Conductors of an overfill controller must not, under any circumstances, be put in the same casing pipe with the wires and cables of other electric circuits.

Connect the protective jacket of the cable to the grounding screw inside the sensor box (Fig. 6) with the accompanying cable terminal.

THE OTHER END OF THE PROTECTIVE JACKET MUST NOT BE CONNECTED TO ANYTHING!

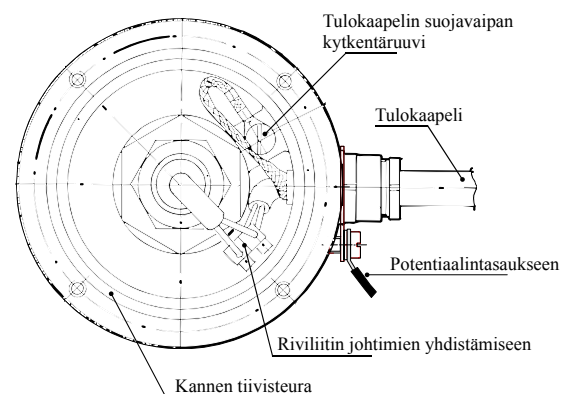

Figure 6.

Connect the cable entering the connection box to the sensor conductors with the accompanying terminal strip.

Connect the brown conductor of the sensor to the (+) pole and the blue conductor to the (-) pole of the inlet.

The incoming cable must be installed so that the plastic overshath enters the connection box by approx. 2 mm. This is to ensure that the conductor becomes watertight when fixed to the rubber gasket of the entry bush.

Tighten firmly the tension screw of the entry bush.

Make sure that the seal of the sensor connection box cover is placed firmly in its groove and then set the cover in place.

Remember to tighten all screws.

Connect the screw next to the entry bush of the incoming cable with a cable of at least 2.5 mm² to the equipotential bonding, or in case of a metal-frame tank, to the frame of the tank. Make sure that the connection is tight and permanent!

4. TESTING AND MAINTENANCE

Check the operation of the sensor with a testing

apparatus.

Fill in the installation records (one copy for the tank owner for the purpose of a fire inspection and a second copy for the assembler).



In connection with maintenance, inspection and reparation operations, instructions provided in standards IEC 60079-17 and IEC 60079-19 concerning the inspection and maintenance of Ex devices need to be followed.

Declaration of conformity

This declaration certifies that the below mentioned apparatus conforms with the essential requirements of the ATEX directive 94/9/EC

Description of the apparatus:

Level sensor of tank overfill protection

Type: YTE-101 ATEX: Ex II 1 G Ex ia IIC T3 Ga

Manufacturer: Jotel Oy
Ilkontie 1
36240 Kangasala
FINLAND

ATEX:

EN 60079-0: 2006 Electrical apparatus for explosive atmospheres,
General requirements
EN 60079-11: 2007 Explosive atmospheres – Equipment protection
by intrinsic safety "i"
EN 60079-26: 2007 Explosive atmospheres – Equipment with
equipment protection level (EPL) Ga

EC-type examination certificate: **VTT 07 ATEX 055X**

Notified body: VTT Expert Services Oy, notified body number 0537
Address of the notified body: P.O.Box 1001, FI-02044 VTT, Finland

Production quality assurance notification: VTT 06 ATEX Q 001

Signature

The authorized signatory to this declaration, on behalf of the manufacturer, and the Responsible Person based within the EU, is identified below.

Kangasala 7.12.2010



Jari Ontronen
General Manager
Jotel Oy

YLITÄYTÖNESTIMEN ANTURIN ASENNUSPÖYTÄKIRJA

Laitteiston haltija _____

Laitteiston osoite _____

SÄILIÖ

- | Malli | Sijointus | Rivisäiliö |
|--|--|------------------------------------|
| <input type="checkbox"/> suorakulmainen | <input type="checkbox"/> sisälle | <input type="checkbox"/> Kpl |
| <input type="checkbox"/> lieriömäinen, makaava | <input type="checkbox"/> maan pinnalle | |
| <input type="checkbox"/> lieriömäinen, pysty | <input type="checkbox"/> maan alle | |
| | <input type="checkbox"/> suojakammioon | |

Tilavuus _____ m³

Halkaisija _____ mm

Korkeus _____ mm

ANTURI

Valmistaja: Jotel Oy
Malli: YTE-101

Asennussyvyys (säiliön katto - termistori) _____ mm
(vastaten enintään 95% täyttöastetta lämmitysöljyllä)

SIJOITUS

- säiliön vaipan yläpintaan tai kattoon
- kulkuaukon kanteen
- säiliön seinämään
- säiliön vaippaan
- muhviin
- rivisäiliöön (siihen osaan, joka täyttyy ensin)
asetteluputki asennettu vähintään 25 mm ilmaputken suuaukon alapuolelle

MUUTA

- Ilmaputken suuaukko säiliössä enintään 50 mm säiliön vaipan yläpinnan tai katon alapuolella
- säiliössä mekaaninen ylitäytönestín poistettu
- säiliössä akustinen täyttöhälytin poistettu
- täyttöliitännän läheisyyteen kiinnitetty asianomaiset kilvet
- tarkastus tehty testerin avulla

Täten vakuutan, että yllä mainittu anturi on asennettu valmistajan ohjeiden mukaisesti.

Asennusliike _____

Osoite _____

Päiväys _____

Asennusliikkeen edustajan allekirjoitus ja nimenselvennys

1 kpl säiliön haltijalle (palotarkastusta varten)

1 kpl asentajalle

YLITÄYTÖNESTIMEN ANTURIN ASENNUSPÖYTÄKIRJA

Laitteiston haltija _____

Laitteiston osoite _____

SÄILIÖ

- | Malli | Sijointus | Rivisäiliö |
|--|--|------------------------------------|
| <input type="checkbox"/> suorakulmainen | <input type="checkbox"/> sisälle | <input type="checkbox"/> Kpl |
| <input type="checkbox"/> lieriömäinen, makaava | <input type="checkbox"/> maan pinnalle | |
| <input type="checkbox"/> lieriömäinen, pysty | <input type="checkbox"/> maan alle | |
| | <input type="checkbox"/> suojakammioon | |

Tilavuus _____ m³

Halkaisija _____ mm

Korkeus _____ mm

ANTURI

Valmistaja: Jotel Oy
Malli: YTE-101

Asennussyvyys (säiliön katto - termistori) _____ mm
(vastaten enintään 95% täyttöastetta lämmitysöljyllä)

SIJOITUS

- säiliön vaipan yläpintaan tai kattoon
- kulkuaukon kanteen
- säiliön seinämään
- säiliön vaippaan
- muhviin
- rivisäiliöön (siihen osaan, joka täyttyy ensin)
asetteluputki asennettu vähintään 25 mm ilmaputken suuaukon alapuolelle

MUUTA

- Ilmaputken suuaukko säiliössä enintään 50 mm säiliön vaipan yläpinnan tai katon alapuolella
- säiliössä mekaaninen ylitäytönestín poistettu
- säiliössä akustinen täyttöhälytin poistettu
- täyttöliitännän läheisyyteen kiinnitetty asianomaiset kilvet
- tarkastus tehty testerin avulla

Täten vakuutan, että yllä mainittu anturi on asennettu valmistajan ohjeiden mukaisesti.

Asennusliike _____

Osoite _____

Päiväys _____

Asennusliikkeen edustajan allekirjoitus ja nimenselvennys

1 kpl säiliön haltijalle (palotarkastusta varten)

1 kpl asentajalle