

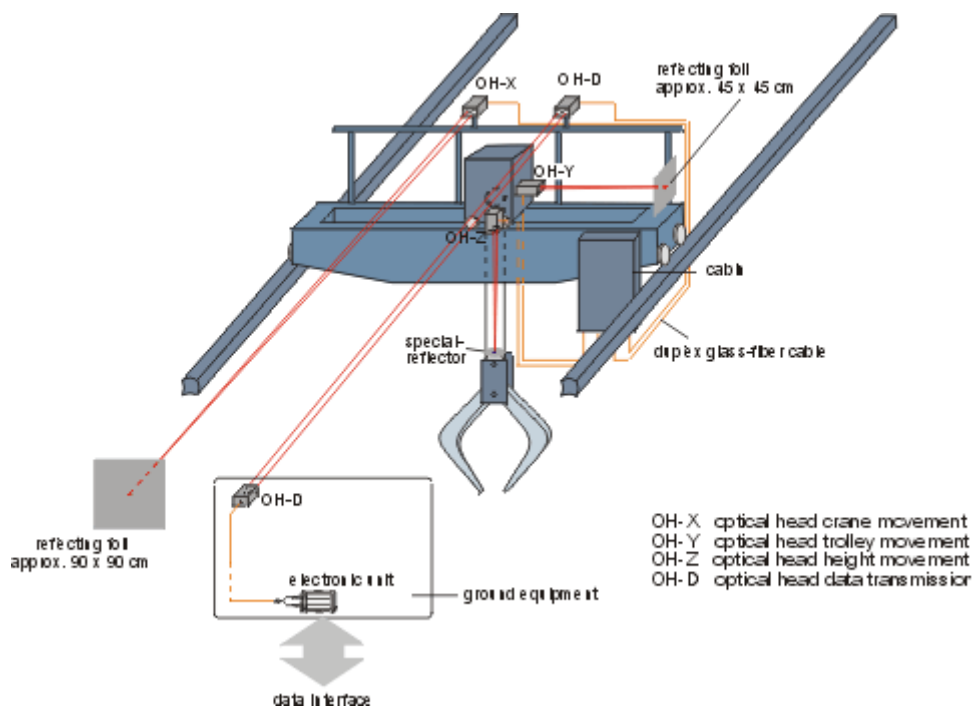

# Automatic Crane Positioning

## Solution:

Optical range measurement in three axes with three [LD90-3100HS-GF](#) instruments with fiber-coupled optical head, and a DL90-600 for data transmission.



## Wesmar AB

Box 1120 · 164 22 Kista  
Finlandsgatan 24 · 16474 Kista  
Tel. 08-544 715 50 · Fax. 08-544 715 60  
Info@wesmar.se · www.wesmar.se

### *Arrangement of electronic unit with cabin fixed to trolley*

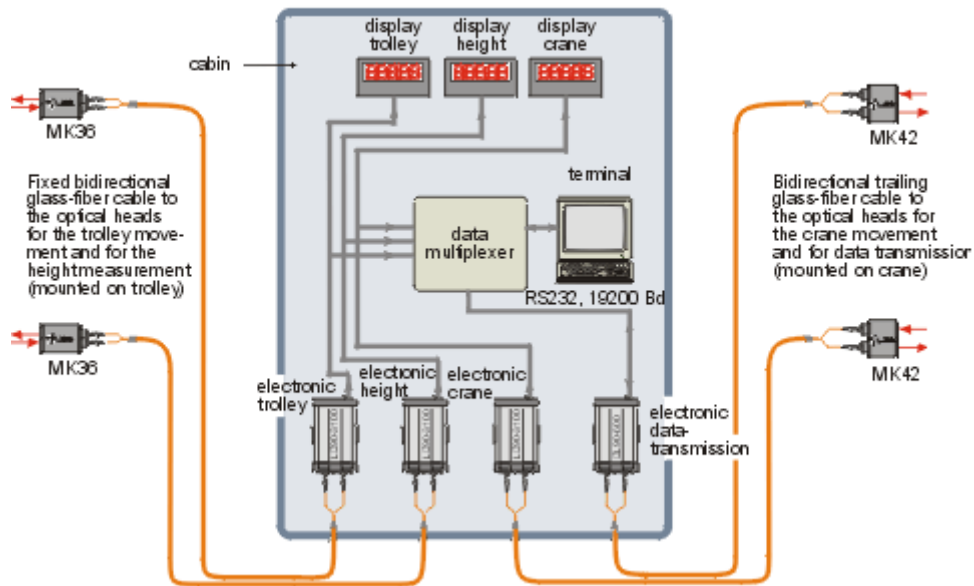

#### **Advantages:**

- No electronics contained in the optical heads
- Extremely lightweight and inexpensive optical heads
- Installation of electronic units in protected area
- Easy and cost-effective replacement of parts of the system in case of servicing requirements

#### **Performance:**

- Maximum range: up to 600 m
- Accuracy: typically 20 mm
- Free line-of-sight required

#### **Related Applications:**

- Crane collision avoidance
- Optical data transfer

# **Wesmar AB**

**Box 1120 · 164 22 Kista  
Finlandsgatan 24 · 16474 Kista  
Tel. 08-544 715 50 · Fax. 08-544 715 60  
Info@wesmar.se · www.wesmar.se**